

Operating Instructions

Robacta TC 2000
Robacta TC 2000 Twin
Robacta TC 2000 Ø35
Robacta TC 2000 LH TWIN
Robacta TC 2000 US
Robacta TC 2000 Twin US
Robacta TC 2000 Ø1.181inch US
Robacta TC 2000 LH TWIN US

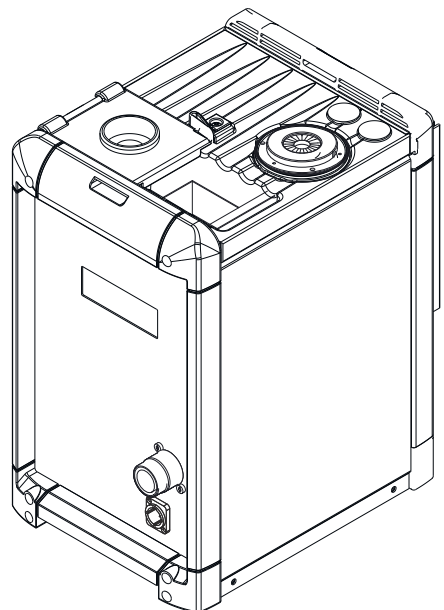

Contents

Safety rules.....	5
Explanation of safety notices	5
General.....	5
Proper use	6
Environmental conditions.....	6
Obligations of the operator.....	6
Obligations of personnel.....	6
Specific hazards.....	7
Protecting yourself and others.....	7
Risks from mains current and operating current.....	8
EMC Device Classifications.....	9
EMC measures.....	9
Safety measures at the installation location and during transport.....	9
Safety measures in normal operation.....	10
Commissioning, maintenance and repair.....	10
Safety inspection.....	11
Disposal.....	11
Safety symbols.....	11
Data protection	11
Copyright.....	11
General	13
General.....	15
Device concept.....	15
Application areas.....	15
Warning notices on the device.....	15
Parting agent types and their use.....	17
Functional principle.....	18
Functional principle.....	18
Magnetic flux densities within the cleaning coil for Robacta TC 2000, Robacta TC 2000 US.....	20
Magnetic flux densities within the cleaning coil for Robacta TC 2000 Twin, Robacta TC 2000 Twin US	21
Scope of supply and options.....	22
General.....	22
Scope of supply.....	22
Available options	22
Transport.....	23
Transport devices	23
Transport notices on the packaging.....	23
Controls, connections and mechanical components	25
Safety	27
Safety	27
Standard I/O connecting plug (X1) pin assignment for robot control.....	28
General.....	28
Standard I/O connecting plug (X1) pin assignment.....	28
Controls, connections and mechanical components.....	30
General.....	30
Control panel.....	30
Robacta TC 2000, Robacta TC 2000 US connections and mechanical components.....	32
Robacta TC 2000 Twin, Robacta TC 2000 Twin US connections and mechanical components	34
Installation and commissioning	37
Safety	39
Safety	39
Before commissioning.....	40

Operators, maintenance personnel.....	40
Setup regulations.....	40
Compressed air supply specifications.....	40
Mains connection.....	41
Bolting the cleaning device to the underlying surface (foundation).....	42
Screwing the cleaning device and installation stand to the underlying surface (foundation).....	42
Connecting the mains cable.....	43
Connecting the mains cable.....	43
Installing the wire cutter.....	44
Installing the wire cutter on the cleaning device.....	44
Maximum wire diameter.....	44
How the mechanically controlled wire cutter works.....	44
How the electrically-controlled wire cutter works.....	45
Filling the dipping bowl with parting agent.....	46
Filling the dipping bowl with parting agent.....	46
Connecting the cleaning device to the "Robacta Reamer" parting agent container.....	47
Connecting the cleaning device to the "Robacta Reamer" parting agent container.....	47
Starting up the cleaning device.....	48
General.....	48
Prerequisites for start-up.....	48
Gas nozzle to spool body distance control.....	48
Cleaning program sequence - Robacta TC 2000, Robacta TC 2000 US.....	49
Program sequence with parting agent nebuliser - overview.....	49
Program sequence with parting agent nebuliser and dipping bowl - overview.....	49
Cooling welding torch in the dipping bowl - detailed description.....	49
Cleaning the gas nozzle tip and nozzle fitting - detailed description.....	50
Spraying parting agent - detailed description.....	50
Cleaning program sequence with parting agent nebuliser.....	52
Cleaning program sequence with dipping bowl.....	53
Cleaning program sequence - Robacta TC 2000 Twin, Robacta TC 2000 Twin US.....	54
Program sequence with parting agent nebuliser - overview.....	54
Program sequence with parting agent nebuliser and dipping bowl - overview.....	54
Cooling welding torch in the dipping bowl - detailed description.....	54
Cleaning the gas nozzle tip and nozzle fitting - detailed description.....	55
Spraying parting agent - detailed description.....	55
Cleaning program sequence with parting agent nebuliser.....	56
Cleaning program sequence with dipping bowl.....	57

Troubleshooting, maintenance and disposal **59**

Safety.....	61
Safety.....	61
Troubleshooting.....	63
Troubleshooting.....	63
Care, maintenance and disposal.....	66
Before each start-up.....	66
Daily.....	66
Weekly.....	66
Every 3 months.....	66
Every 6 months.....	67
Every 12 months.....	67
Disposal.....	67

Technical data **69**

Technical data.....	71
General.....	71
Robacta TC 2000, Robacta TC 2000 Twin.....	71
Robacta TC 2000 US, Robacta TC 2000 Twin US.....	71

Safety rules

Explanation of safety notices

DANGER!

Indicates immediate danger.

- ▶ If not avoided, death or serious injury will result.

WARNING!

Indicates a potentially hazardous situation.

- ▶ If not avoided, death or serious injury may result.

CAUTION!

Indicates a situation where damage or injury could occur.

- ▶ If not avoided, minor injury and/or damage to property may result.

NOTE!

Indicates a risk of flawed results and possible damage to the equipment.

General

The device is manufactured using state-of-the-art technology and according to recognised safety standards. If used incorrectly or misused, however, it can cause:

- injury or death to the operator or a third party,
- damage to the device and other material assets belonging to the operating company,
- inefficient operation of the device.

All persons involved in commissioning, operating, maintaining and servicing the device must:

- be suitably qualified,
- have sufficient knowledge of automated welding, and
- read and carefully follow these operating instructions as well as the operating instructions for all system components.

The operating instructions must always be at hand wherever the device is being used. In addition to the operating instructions, attention must also be paid to any generally applicable and local regulations regarding accident prevention and environmental protection.

All safety and danger notices on the device

- must be in a legible state,
- must not be damaged,
- must not be removed,
- must not be covered, pasted or painted over.

For the location of the safety and danger notices on the device, refer to the section headed "General" in the operating instructions for the device.

Before commissioning the device, rectify any faults that could compromise safety.

This is for your personal safety!

Proper use

The device is to be used exclusively for its intended purpose.

The device is intended solely for the electromagnetic cleaning of Fronius welding torches.

Any use above and beyond this purpose is deemed improper. The manufacturer shall not be held liable for any damage arising from such usage.

Proper use includes:

- carefully reading and following all the instructions given in the operating instructions
- studying and obeying all safety and danger notices carefully
- performing all stipulated inspection and servicing work.

The device is designed for use in industry and the workshop. The manufacturer accepts no responsibility for any damage caused through use in a domestic setting.

The manufacturer likewise accepts no liability for inadequate or incorrect results.

Environmental conditions

Operation or storage of the device outside the stipulated area will be deemed as not in accordance with the intended purpose. The manufacturer shall not be held liable for any damage arising from such usage.

Ambient temperature range:

- during operation: 0 °C to + 40 °C (32 °F to 104 °F)
- during transport and storage: -25 °C to +55 °C (-13 °F to 131 °F)

Relative humidity:

- up to 50 % at 40 °C (104 °F)
- up to 90 % at 20 °C (68 °F)

Keep ambient air free from dust, acids, corrosive gases and substances, etc.

Can be used at altitudes of up to 2000 m (6500 ft)

Obligations of the operator

The operator must only allow persons to work with the device who:

- are familiar with the fundamental instructions regarding safety at work and accident prevention and have been instructed in how to use the device
- have read and understood these operating instructions, especially the section "safety rules", and have confirmed as much with their signatures
- are trained to produce the required results.

Checks must be carried out at regular intervals to ensure that operators are working in a safety-conscious manner.

Obligations of personnel

Before using the device, all persons instructed to do so undertake:

- to observe the basic instructions regarding safety at work and accident prevention
- to read these operating instructions, especially the "Safety rules" section and sign to confirm that they have understood them and will follow them.

Before leaving the workplace, ensure that people or property cannot come to any harm in your absence.

Specific hazards

Stay out of the working area of the robot.

The device must be incorporated into a higher-level safety system within a secured area.

If this area has to be accessed when setup and maintenance work is carried out, make sure that

- the entire system is switched off for the duration of the work in this area
 - and that it is prevented from starting up accidentally, e.g., as the result of a control fault
-

In addition to these operating instructions, the safety rules issued by the robot manufacturer must also be observed.

Covers and side panels may only be opened/removed while maintenance or repair work is being carried out.

During operation:

- Ensure that all covers are closed and all side panels are fitted properly.
 - Keep all covers and side panels closed.
-

Protecting yourself and others

Electromagnetic fields may pose as yet unknown risks to health:

- Effects on the health of persons in the vicinity, for example, those with pacemakers, metallic implants and hearing aids
 - Forbidden for anyone wearing a pacemaker: people wearing a pacemaker must consult their doctor before working with the device or entering its immediate vicinity
 - Forbidden for anyone with metal implants: people who have had metal implants fitted must consult their doctor before working with the device or entering its immediate vicinity
-

Magnetic fields generated by the high amperage can cause ferromagnetic parts such as spatter accumulations to be ejected from the cleaning opening. To prevent injury, never look into in the cleaning opening while the device is switched on; protective goggles with side protection must be worn at all times.

Anyone working with the device exposes themselves to numerous risks e.g.:

- flying sparks and hot pieces of metal
 - Arc radiation, which can damage eyes and skin
 - Risk of electrocution from mains current and welding current
 - Greater noise pollution
 - Harmful welding fumes and gases
-

Suitable protective clothing must be worn when working with the device. The protective clothing must have the following properties:

- Flame-resistant
 - Insulating and dry
 - Covers the whole body, is undamaged and in good condition
 - Safety helmet
 - Trousers with no turn-ups
-

Protective clothing refers to a variety of different items. Operators should:

- Protect eyes and face from UV rays, heat and sparks using a protective visor and regulation filter
- Wear regulation protective goggles with side protection behind the protective visor
- Wear stout footwear that provides insulation even in wet conditions
- Protect the hands with suitable gloves (electrically insulated and providing protection against heat)
- Wear ear protection to reduce the harmful effects of noise and to prevent injury

Keep all persons, especially children, out of the working area while any devices are in operation or welding is in progress. If, however, there are people in the vicinity:

- make them aware of all the dangers (dazzling by arc, injury from flying sparks, inhalation of harmful welding fumes, noise, possible danger from mains or welding current, possible danger from electromagnetic fields, possible danger from the magnetic field around the cleaning opening, mechanically-powered parts, compressed air/parting agent mixture ejected from the cleaning opening, flying shavings and similar matter, etc.),
 - Provide suitable protective equipment
 - Alternatively, erect suitable safety screens/curtains.
-

Risks from mains current and operating current

An electric shock is potentially life threatening and can be fatal.

Do not touch live parts either inside or outside the device.

All cables and leads must be secured, undamaged, insulated and adequately dimensioned. Loose connections, scorched, damaged or inadequately dimensioned cables and leads must be replaced immediately.

Do not sling cables or leads around the body or parts of the body.

Only switch on the device when all output connections have been established correctly.

The device must only be operated on a mains supply with a ground conductor and a socket with a ground conductor contact.

If the device is operated on a mains supply without a ground conductor, this will be deemed as gross negligence. The manufacturer shall not be held liable for any damage arising from such usage.

Arrange for the mains cable to be checked regularly by a qualified electrician to ensure the ground conductor is functioning properly.

Switch off unused devices.

Disconnect the mains plug before working on the device.

Attach a clearly legible and easy-to-understand warning sign to the device to prevent anyone from plugging the mains plug back in and switching it on again.

After opening the device:

- Discharge all live components
- Ensure that all components in the device are de-energised.

If work on live parts is required, appoint a second person to switch off the main switch at the right moment.

The housing screws provide an adequate ground conductor connection for earthing the housing. The screws must never be replaced with different screws unless a reliable ground conductor connection is set up.

EMC Device Classifications

Devices in emission class A:

- Are only designed for use in industrial settings
- Can cause line-bound and radiated interference in other areas

Devices in emission class B:

- Satisfy the emissions criteria for residential and industrial areas. This is also true for residential areas in which the energy is supplied from the public low-voltage mains.

EMC device classification as per the rating plate or technical data.

EMC measures

Warning, electromagnetic field. Electromagnetic fields may pose as yet unknown risks to health.

It is the operator's responsibility to ensure that no electromagnetic interference occurs in electrical and electronic devices.

If electromagnetic interference is detected, the operator is obliged to take action to rectify the situation.

Check for possible problems, and check and evaluate neighbouring devices' resistance to interference according to national and international requirements:

- Safety devices
- Power, signal and data transfer lines
- IT and telecommunications devices
- Measuring and calibrating devices
- Health of neighbouring persons

Supporting measures for avoidance of EMC problems:

1. Mains supply
 - If electromagnetic interference arises despite the correct mains connection, additional measures are necessary (e.g. use of a suitable line filter)
2. Shielding, if necessary
 - Shield off other nearby devices
 - Shield off entire welding installation
3. Do not have any magnetic or electronic data carriers about your person: magnetic or electronic data carriers can be damaged by the magnetic fields generated when the device is in use.
4. Do not have any watches or pieces of metal about your person. Watches can be damaged when the device is in use.

Safety measures at the installation location and during transport

A device toppling over could easily kill someone. Place the device on a solid, level surface such that it remains stable

- The maximum permissible tilt angle is 10°.

Special regulations apply in rooms at risk of fire or explosion

- Observe relevant national and international regulations.

Use internal directives and checks to ensure that the workplace environment is always clean and clearly laid out.

Only set up and operate the device in accordance with the degree of protection shown on the rating plate.

When setting up the device, ensure an all-round clearance of at least 0.5 m (19.69 in.) from any surrounding objects, e.g. walls, other devices or objects.

The device must be set up at least 1 m (40 in.) away from computers, control lines and the welding process.

Position the device to prevent welding spatter coming into contact with the cleaning device.

Before transporting the device, allow parting agent to drain completely.

When transporting the device, observe the relevant national and local guidelines and accident prevention regulations. This applies especially to guidelines regarding the risks arising during transport.

After transporting the device, the device must be visually inspected for damage before commissioning. Any damage must be repaired by trained service technicians before commissioning the device.

Safety measures in normal operation

Only operate the device when all safety devices are fully functional. If the safety devices are not fully functional, there is a risk of

- injury or death to the operator or a third party,
 - damage to the device and other material assets belonging to the operator,
 - inefficient operation of the device.
-

Any safety devices that are not functioning properly must be repaired before switching on the device.

Never bypass or disable safety devices.

Before switching on the device, ensure that no one is likely to be endangered.

Check the device at least once a week for obvious damage and proper functioning of safety devices.

- Only use suitable original parting agent from the manufacturer.
 - Observe the information on the parting agent safety data sheets when handling parting agent. The parting agent safety data sheets may be obtained from your service centre or downloaded from the manufacturer's website.
 - Do not mix the manufacturer's parting agent with other parting agents.
 - If damage results from using a different parting agent, the manufacturer accepts no liability. In addition, no warranty claims will be entertained.
 - Used parting agent must be disposed of properly in accordance with the relevant national and international regulations.
-

Commissioning, maintenance and repair

It is impossible to guarantee that bought-in parts are designed and manufactured to meet the demands made of them, or that they satisfy safety requirements.

- Use only original spare and wearing parts (also applies to standard parts).
 - Do not carry out any modifications, alterations, etc. to the device without the manufacturer's consent.
 - Components that are not in perfect condition must be replaced immediately.
 - When ordering, please give the exact designation and part number as shown in the spare parts list, as well as the serial number of your device.
-

The housing screws provide the ground conductor connection for earthing the housing parts.

Only use original housing screws in the correct number and tightened to the specified torque.

Safety inspection	<p>The manufacturer recommends that a safety inspection of the device is performed at least once every 12 months.</p> <hr/> <p>A safety inspection should be carried out by a qualified electrician</p> <ul style="list-style-type: none">- after any changes are made- after any additional parts are installed, or after any conversions- after repair, care and maintenance has been carried out- at least every twelve months. <hr/> <p>For safety inspections, follow the appropriate national and international standards and directives.</p> <hr/> <p>Further details on safety inspection and calibration can be obtained from your service centre. They will provide you on request with any documents you may require.</p>
Disposal	<p>Waste electrical and electronic equipment must be collected separately and recycled in an environmentally responsible manner in accordance with the EU Directive and national law. Used equipment must be returned to the distributor or through a local, authorised collection and disposal system. Proper disposal of the old device promotes sustainable recycling of material resources. Ignoring this may lead to potential health/environmental impacts.</p> <p>Packaging materials Collected separately. Check your municipality's regulations. Reduce the volume of the box.</p>
Safety symbols	<p>Devices with the CE mark satisfy the essential requirements of the low-voltage and electromagnetic compatibility directives (e.g. relevant product standards of the EN 60 974 series).</p> <p>Fronius International GmbH hereby declares that the device is compliant with Directive 2014/53/EU. The full text on the EU Declaration of Conformity can be found at the following address: http://www.fronius.com</p> <hr/> <p>Devices marked with the CSA test mark satisfy the requirements of the relevant standards for Canada and the USA.</p>
Data protection	<p>The user is responsible for the safekeeping of any changes made to the factory settings. The manufacturer accepts no liability for any deleted personal settings.</p>
Copyright	<p>Copyright of these operating instructions remains with the manufacturer.</p> <hr/> <p>The text and illustrations are all technically correct at the time of printing. We reserve the right to make changes. The contents of the operating instructions shall not provide the basis for any claims whatsoever on the part of the purchaser. If you have any suggestions for improvement, or can point out any mistakes that you have found in the instructions, we will be most grateful for your comments.</p>

General

Device concept

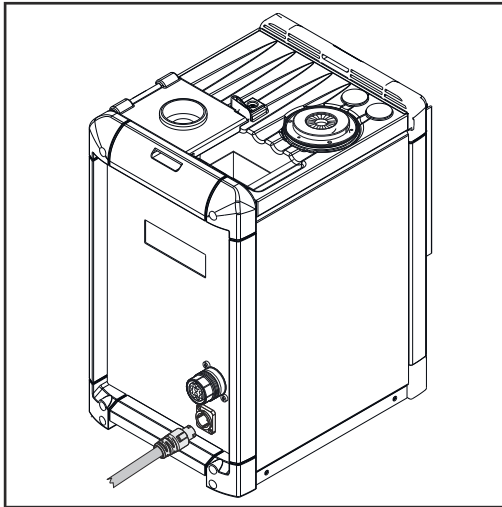

Robacta TC 2000

The cleaning devices in the Robacta TC 2000 series have been designed to clean a variety of different welding torch geometries. The components are contained in a robust housing. The compact design means it can be set up in the narrowest of spaces (e.g. in robot cells). In addition, the cleaning devices have been conceived in such a way that the installation stand and standard I/O connecting plug (X1) of the Robacta TC 1000 can be used with the cleaning devices without any modifications.

The cleaning devices are more or less maintenance-free, as there are no mechanically stressed parts.

Application areas

The cleaning device cleans welding torches in automated steel applications. It has been designed for use in the





- automotive and component supply industry
- equipment construction
- chemical plant construction
- mechanical engineering
- rolling stock construction
- shipyards

Warning notices on the device

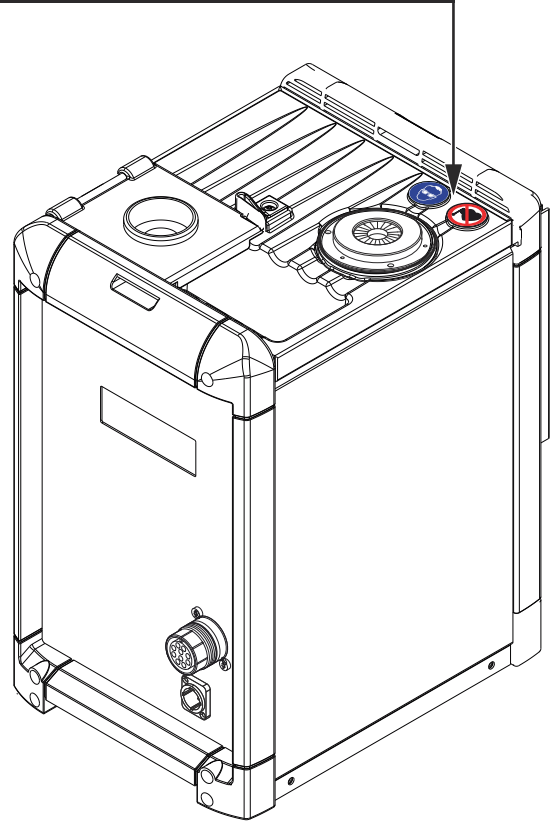
The device is fitted with safety symbols and a rating plate. The safety symbols and rating plate must not be removed or painted over. The symbols warn against operating the equipment incorrectly, as this could result in serious injury or damage to property.





		Type:		
		Art.No.:		
		Ser.No.:		
A-4600 Wels www.fronius.com				
	U _i	230 V	U _{control}	24 V
	I ₁	4A	t _{cycle min}	20 sec.
	P _{max}	6bar (87PSI)	IP 21	
				
<p>WARNING: Before servicing, cleaning or removal of any part, shut off power and relieve pressure.</p> <p>AVERTISSEMENT: Couper le courant et détendre à la pression atmosphérique avant de procéder au dépannage, au nettoyage, ou d'enlever toute pièce.</p>				



WARNING! Risk of serious injury from:

- The magnetic field surrounding the cleaning opening
- Compressed air/parting agent mixture escaping from the cleaning opening
- Flying parts (shavings, etc.)
- Mechanically powered components

Keep device free from current and pressure during maintenance and servicing.



Do not use the functions described here until you have fully read and understood the following documents:

- These Operating Instructions
- All the Operating Instructions for the system components, especially the safety rules

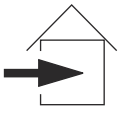

For indoor use only



Wear eye protection



Forbidden for anyone wearing a pacemaker

Parting agent types and their use

NOTE!

Parting agents are not included in the scope of supply.

Parting agent types and their use:

- "Robacta TC Cool +" parting agent for immersing the welding torch in the dipping bowl
- "Robacta Reamer" parting agent for spraying the welding torch after the cleaning operation

It is recommended that the dipping bowl should be used for:

- Gas-cooled welding torches
- Water-cooled welding torches in the upper power range (hot gas nozzles)

Spraying the welding torch with "Robacta Reamer" parting agent is recommended for all applications.

Functional principle

Functional principle

- Once the cleaning device is connected to the mains power supply, the mains voltage indicator lights up. The capacitors, which store energy for the cleaning operation, are discharged and no outputs are activated.

NOTE!

Before the capacitors can be charged, the cleaning device must be connected to both the mains power supply and the robot control. The "Quick Stop" signal must also be set.

- The device temperature is checked before the capacitors are charged. If it lies within the tolerance range, the capacitors are charged in preparation for a cleaning operation. If the operating temperature is exceeded, the overtemperature indicator lights up. Capacitor charging only begins once the temperature has fallen to the permitted operating temperature.
- The "Ready" signal is output to the robot control after twenty seconds of charging - the "Ready-to-discharge" indicator on the device begins to flash. When the capacitors are fully charged, the light remains permanently on. Although the device has still not achieved maximum magnetic flux density after just twenty seconds, the cleaning operation (discharge process) can still be triggered using the "Cleaning Start" signal. For adjustment purposes, the cleaning operation can also be manually triggered using the discharge button on the device.

The maximum magnetic flux density for cleaning is available after fifty seconds of charging.

See the diagram below for the exact relationship between charging time and the magnetic flux density available.

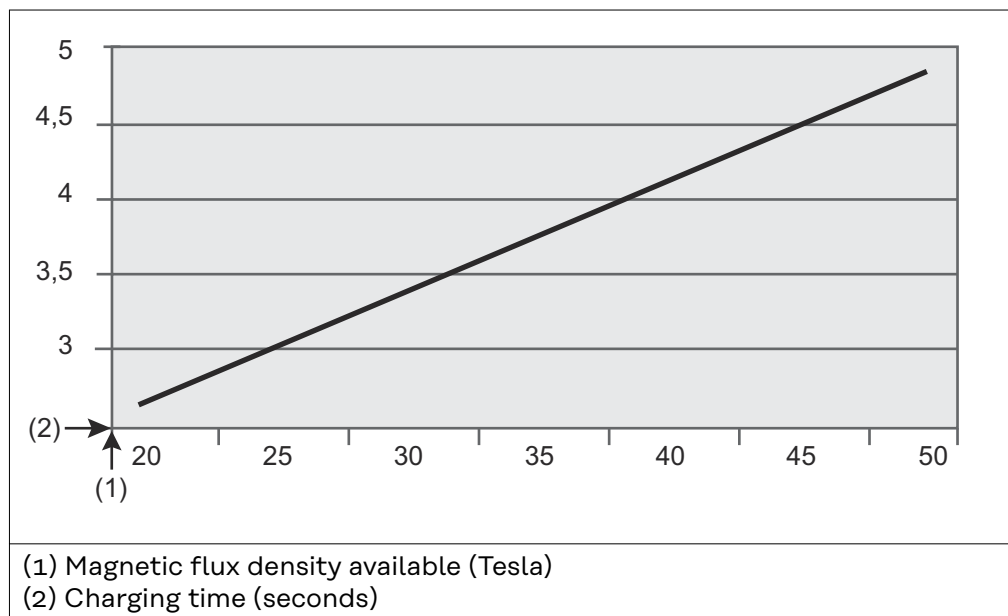

- Once the cleaning operation is complete, the program sequence restarts by checking the device's temperature. If there was a problem during the cleaning operation, the "Error" signal is output. The cleaning device resumes charging the capacitors. Once ready to clean ("Ready"), a second cleaning operation can be started.

NOTE!

If the robot control deactivates the "Quick Stop" signal during the program sequence, the cleaning device program sequence is interrupted immediately. For safety reasons the capacitors are discharged via the cleaning coil.

- Automatic refilling of the dipping bowl with "Robacta TC Cool +" parting agent ensures an optimum fill level in the dipping bowl. After draining the "Robacta TC Cool +" parting agent container, the fill level in the dipping bowl drops. The level sensor detects that the level has dropped too low and the fill level indicator lights up. At the same time, the "Fluid level control" signal is transmitted to the robot control.
 - The device cleaning function remains available even if the fill level indicator is illuminated.

Magnetic flux densities within the cleaning coil for Robacta TC 2000, Robacta TC 2000 US

Depending on the application, the strength of the magnetic flux density on the individual areas of the welding torch can be controlled by regulating how deeply the welding torch is immersed in the cleaning coil.

NOTE!

When using the cleaning device, refer to the program sequence for details of the welding torch immersion depth.

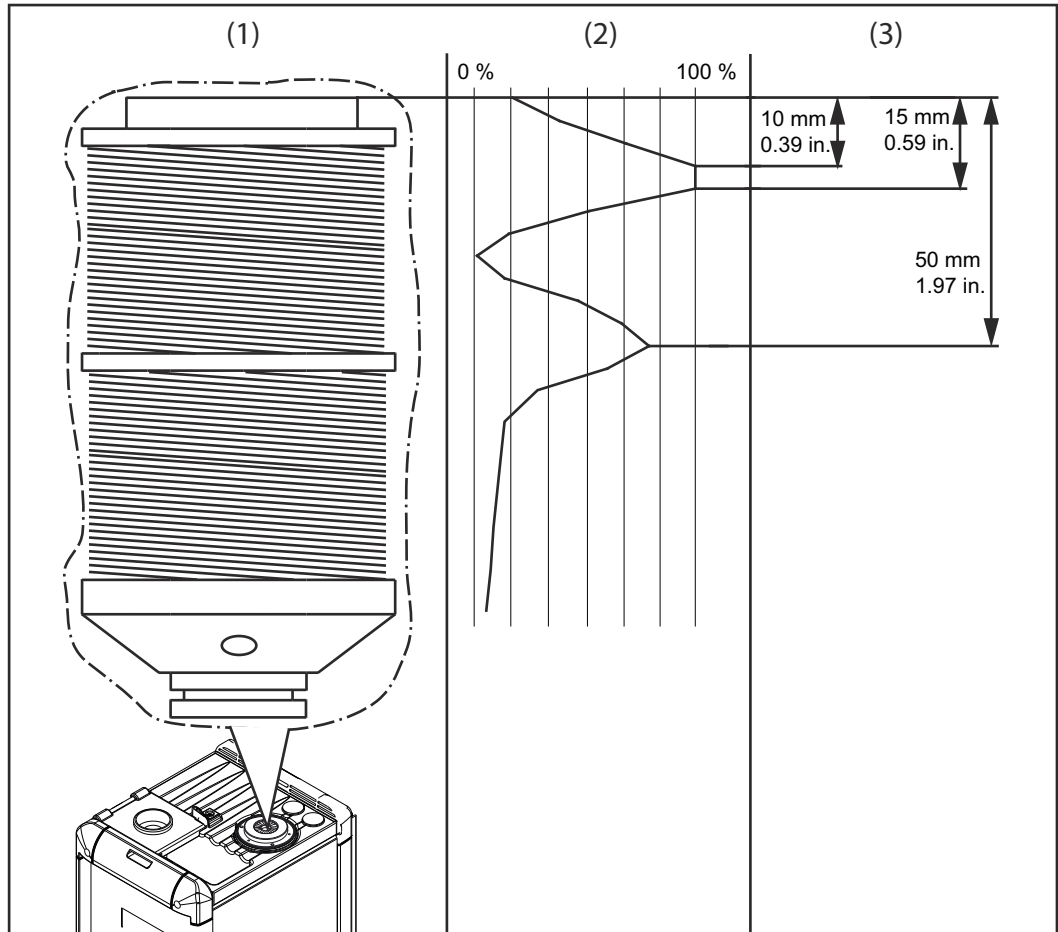

(1) Cleaning coil

(2) Diagram showing available magnetic flux density

(3) Immersion depth of torch neck into cleaning coil

Magnetic flux densities within the cleaning coil for Robacta TC 2000 Twin, Robacta TC 2000 Twin US

Depending on the application, the strength of the magnetic flux density on the individual areas of the welding torch can be controlled by regulating how deeply the welding torch is immersed in the cleaning coil.

NOTE!

When using the cleaning device, refer to the program sequence for details of the welding torch immersion depth.

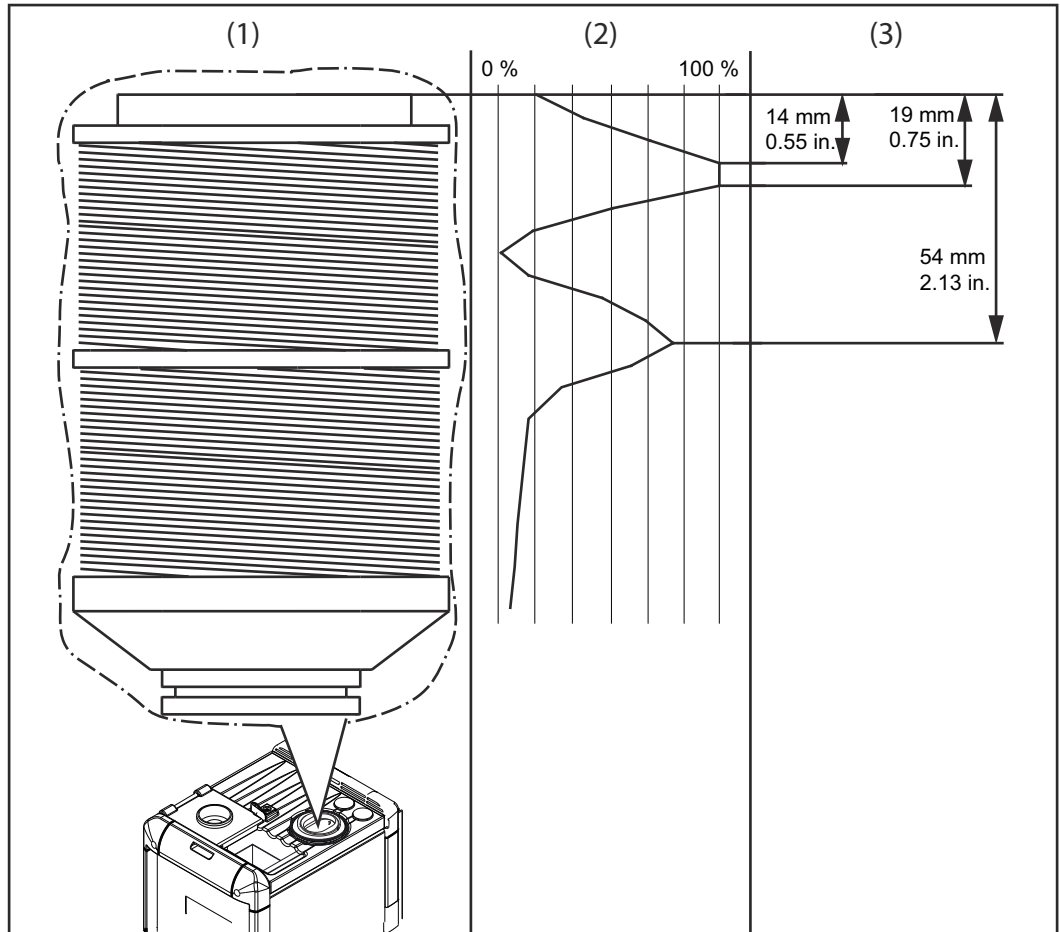

(1) Cleaning coil

(2) Diagram showing available magnetic flux density

(3) Immersion depth of torch neck into cleaning coil

Scope of supply and options

General

The cleaning device may be operated in conjunction with various options. Depending on the area of application, various sequences in the work process can be optimized as a result.

Scope of supply

- Cleaning device with dipping bowl and integrated cleaning unit
 - Standard I/O connecting plug (X1) without cable
 - Four screws for fitting the cleaning device to the installation stand
-

Available options

Available options for the cleaning device

- Installation stand (available in various heights)
- Wire cutter
- Wire cutter installation kit
- Parting agent nebuliser installation kit
- Robot interface

Transport

Transport devices

The device is to be transported by the following devices:

- On pallets using a forklift truck
- On pallets using a lift truck
- Manual

 **WARNING!**

Danger from machines and objects falling.

This can result in serious injury and damage to property.

- ▶ Secure the device to prevent it from falling over when transporting on a forklift truck or lift truck.
 - ▶ Avoid sudden changes in direction, braking or acceleration.
-

Transport notices on the packaging

 **CAUTION!**

Danger due to improper transport.

This can result in damage to property.

- ▶ Observe the transport notices on the device packaging.
-

Controls, connections and mechanical components

Safety

Observe the following safety rules for all work described in the "Control elements, connections and mechanical components" section.



WARNING!

Danger due to incorrect operation and incorrectly performed work.

This can result in serious injury and damage to property.

- ▶ All the work and functions described in this document must only be carried out by trained and qualified personnel.
 - ▶ Read and understand this document.
 - ▶ Read and understand all the Operating Instructions for the system components, especially the safety rules.
-

Standard I/O connecting plug (X1) pin assignment for robot control

General

WARNING!

Danger from electric current.

This can result in serious personal injury and damage to property.

- ▶ The cleaning device must remain de-energised until the installation is fully complete.
-

NOTE!

To avoid malfunctions, keep the cable length between the cleaning device and robot control as short as possible.

The standard I/O connecting plug (X1) for connecting the cleaning device to the robot control is part of the scope of supply. Adapt the cable harness to the connection technology on the robot control.

Standard I/O connecting plug (X1) pin assignment

WARNING!

Danger due to unexpectedly activated cleaning device/unexpectedly activated system components.

This can result in serious personal injury and damage to property.

- ▶ Only assign the Quick Stop signal input with HIGH or
 - ▶ Only assign the Quick Stop signal input with LOW
-

NOTE!

Depending on the demands placed on the robot application, not all input and output signals (commands) need to be used.

The underlined I/O signals in the following figure represent the minimum command subset required in all applications.

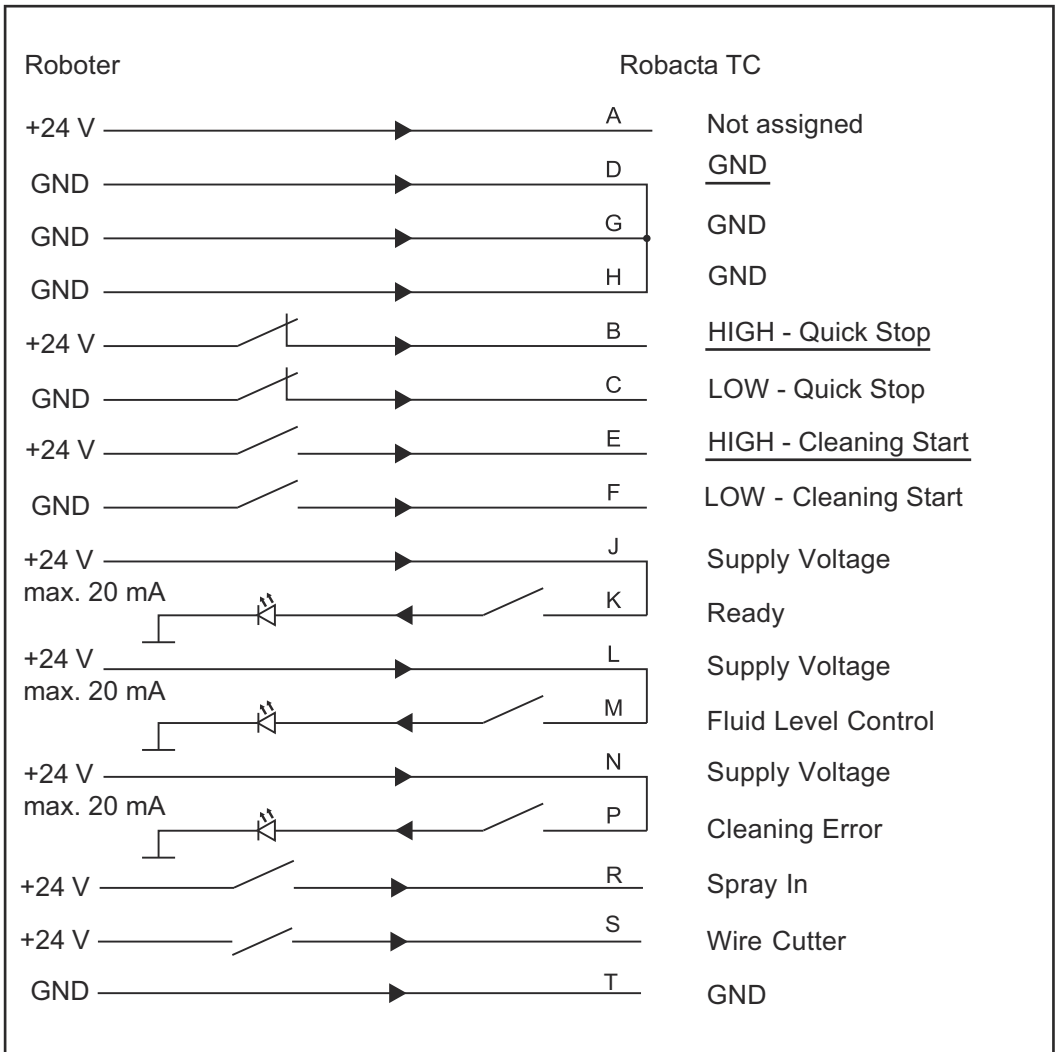

Standard I/O connecting plug (X1) pin assignment

Controls, connections and mechanical components

General

All functions of the cleaning unit are activated by the robot control. For adjustment, the cleaning operation can be manually triggered on the control panel.

NOTE!

The individual illustrations may differ slightly from your device.

However, the functioning of the controls and the connections is identical.

Control panel

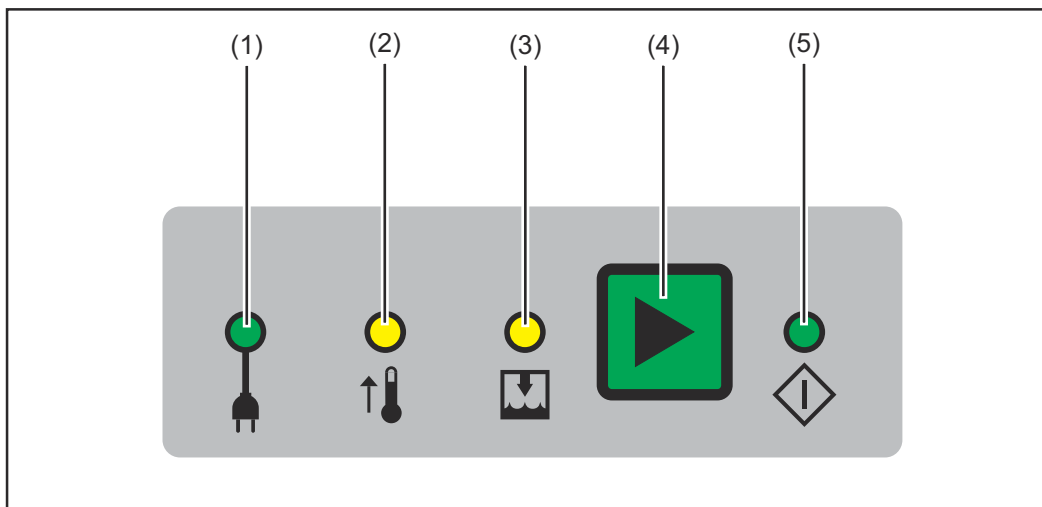

(1) Mains voltage indicator

lights up when the device is powered by mains voltage

NOTE!

If the capacitors in the device are charged, they will discharge automatically as soon as the device is unplugged from the mains. Discharge time is approx. 1 second.

(2) Overtemperature indicator

lights up when the device overheats

NOTE!

One more cleaning operation can be carried out after this indicator lights up. Only once the device has cooled back down to the operating temperature will the device recharge in preparation for the next cleaning operation.

(3) Fill level indicator

will come on

- if the fill level in the dipping bowl drops below minimum
- if the dipping bowl is not used, hence there is no parting agent in the dipping bowl

NOTE!

If the dipping bowl in use, it should be refilled with parting agent as soon as the fill level indicator lights up.

NOTE!

The cleaning function of the Robacta TC remains available even if the fill level indicator is illuminated.

(4) Discharge key

press the key briefly; the cleaning device will perform the following functions:

1. Cleaning is started

press and hold the key; the cleaning device will perform the following functions in sequence:

1. Cleaning is started
2. Wire cutter is activated
3. Compressed air/parting agent mixture is sprayed out of the cleaning opening

NOTE!

The cleaning device can only perform these functions if the "Quick Stop" signal is set and the capacitors are charged.

(5) Ready-to-clean indicator

lights up when the device is ready to clean

Robacta TC 2000, Robacta TC 2000 US connections and mechanical components

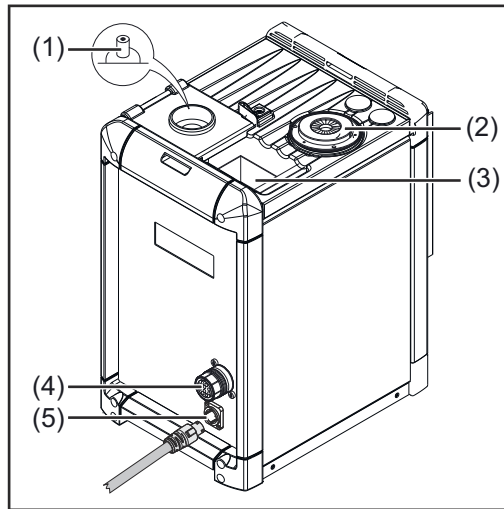

Front of device

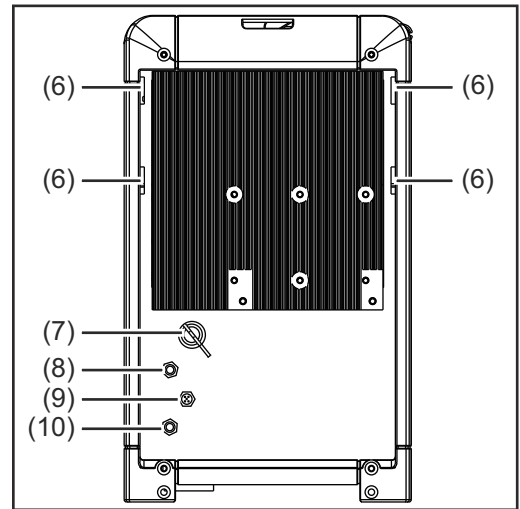

Rear of device

- (1) Level sensor**
monitors the parting agent fill level in the dipping bowl

- (2) Cleaning opening with internal parting-agent injection nozzle and brush seal**
for cleaning the gas nozzle and the inside of the welding torch
for coating the gas nozzle and welding torch interior with parting agent

NOTE!

To avoid excess soiling, only use the device with the brush seal in place.

- (3) Dipping bowl with spill tray**

NOTE!

If the dipping bowl is not in use, ensure that there are no parting agent residues left in the bottom.

NOTE!

Ensure that there is always sufficient parting agent in the dipping bowl when in use (i.e. ensure that the fill level indicator never lights up).

- (4) Standard I/O (X1) connection**

- (5) Mains cable connection**

- (6) Recesses for the wire cutter holder**
for attaching the wire cutter holder to the cleaning device

- (7) Drain hose**
for emptying the dipping bowl

- (8) Parting agent nebuliser connection**
for connecting to the "Robacta Reamer" parting agent container; for spraying the compressed air/parting agent mixture into the cleaning opening



-
- (9) Wire cutter connection**
for electrically controlling the wire cutter



-
- (10) Compressed air connection**
for supplying the cleaning device with compressed air

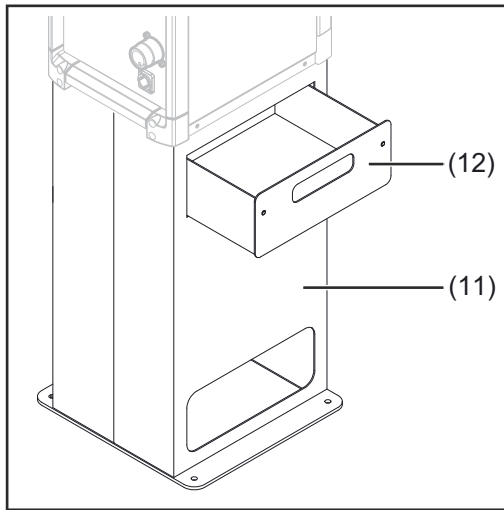

-
- (11) Installation stand (option)**

-
- (12) Spatter tray for welding residues**
-

**Robacta TC
2000 Twin,
Robacta TC
2000 Twin US
connections and
mechanical com-
ponents**

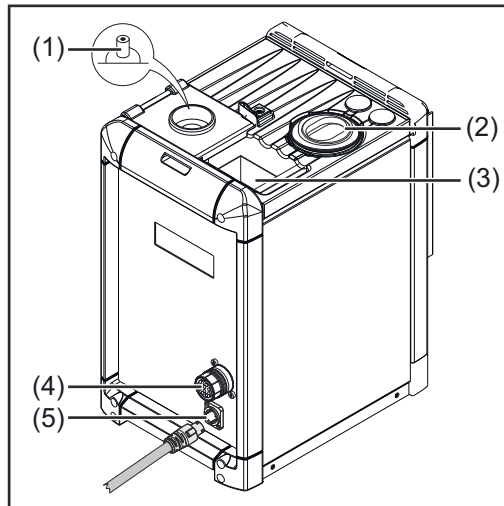

Front of device

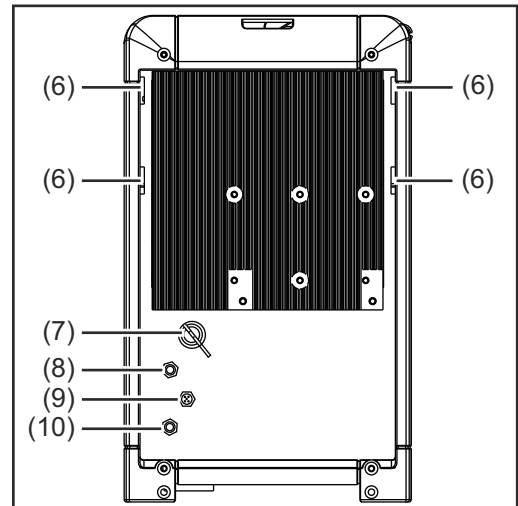

Rear of device

- (1) Level sensor**
monitors the parting agent fill level in the dipping bowl

- (2) Cleaning opening with internal parting-agent injection nozzle**
for cleaning the gas nozzle and the inside of the welding torch
for coating the gas nozzle and welding torch interior with parting agent

- (3) Dipping bowl with spill tray**

NOTE!

If the dipping bowl is not in use, ensure that there are no parting agent residues left in the bottom.

NOTE!

Ensure that there is always sufficient parting agent in the dipping bowl when in use (i.e. ensure that the fill level indicator never lights up).

- (4) Standard I/O (X1) connection**

- (5) Mains cable connection**

- (6) Recesses for the wire cutter holder**
for attaching the wire cutter holder to the cleaning device

- (7) Drain hose**
for emptying the dipping bowl

- (8) Parting agent nebuliser connection**
for connecting to the "Robacta Reamer" parting agent container; for spraying the compressed air/parting agent mixture into the cleaning opening



- (9) Wire cutter connection**
for electrically controlling the wire cutter



(10) Compressed air connection
for supplying the cleaning device with compressed air

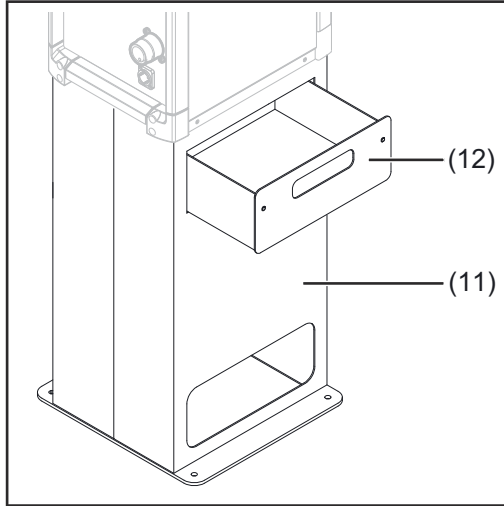

(11) Installation stand (option)

(12) Spatter tray for welding residues

Installation and commissioning

Safety

Observe the following safety rules for all work described in the "Installation and commissioning" section.

WARNING!

Danger from incorrect operation and work that is not carried out properly.

This can result in serious personal injury and damage to property.

- ▶ All the work and functions described in this document must only be carried out by a trained Fronius service technician.
- ▶ Read and understand this document in full.
- ▶ Read and understand all safety rules and user documentation for this device and all system components.

WARNING!

Risk of machines starting automatically.

This can result in serious personal injury and damage to property.

- ▶ In addition to these Operating Instructions, also observe the safety rules issued by the manufacturer of the robot and welding system.
- ▶ Ensure that all protective measures have been taken and will remain in place while you are in the working area of the robot.

WARNING!

Danger from electric current and mechanically powered parts.

This can result in serious personal injury and damage to property.

- ▶ Before working on the cleaning device or the associated system components, disconnect the customer's compressed air and power supply from the cleaning device and the associated system components.
- ▶ Ensure that they remain disconnected until all work is complete.

WARNING!

**Whenever the cleaning device is supplied with voltage and/or compressed air, a risk of serious injury exists from:
the magnetic field of the cleaning opening
flying parts (shavings, etc.)
compressed air/parting agent mixture escaping from the cleaning opening
activated wire cutter**

This can result in serious personal injury and damage to property.

If work has to be performed on the cleaning device while it is being supplied with voltage and/or compressed air, take the following protective measures:

- ▶ Keep all ferromagnetic parts away from the device (e.g. tools).
- ▶ Keep your body, especially your hands, face and hair, any objects and all clothing away from the cleaning opening and the wire cutter.
- ▶ Wear ear protection.
- ▶ Wear protective goggles with side protection.

Before commissioning

Operators, maintenance personnel



WARNING!

Risk of machines starting automatically.

This can result in serious injury and damage to property.

- ▶ The device must only be operated/serviced by 1 person at a time.
 - ▶ Ensure that there is only 1 person within the working area of the device when the device is being worked on.
-

Setup regulations

The device is tested to IP 21, meaning:

- protection against penetration by solid foreign bodies with diameters > 12.5 mm (0.49 in.)
- protection against vertically falling drops of water

The device must not be set up and operated outdoors. The built in electrical parts must be protected from direct wetting.

NOTE!

The device must be set up at least 1 m (40 in.) away from computers, control lines and the welding process.

NOTE!

When setting up the device, ensure an all-round clearance of at least 0.5 m (19.69 in.) from any surrounding objects, e.g. walls, other devices or objects.

NOTE!

Position the device to prevent welding spatter coming into contact with the cleaning device.

Compressed air supply specifications

To ensure that the cleaning device functions correctly, the following compressed air supply specifications must be met:

- Establish compressed air supply using a pressure limiter and compressed air filter
- Provide compressed air quality conforming to ISO 8573-1:2001, class 7 4 3, instrument air
 - Solid particle concentration $\leq 10 \text{ mg/m}^3$
 - Vapour pressure dew point $\leq + 3 \text{ }^\circ\text{C}$
 - Oil concentration $\leq 1 \text{ mg/m}^3$

Mains connection

 **CAUTION!**

Danger due to insufficiently dimensioned electrical installations.

This can result in damage to property.

- ▶ Dimension the mains lead and its fuse to suit the local power supply. The technical data shown on the rating plate applies.
-

 **CAUTION!**

Danger from incorrect mains voltage.

This can result in severe damage to property.

- ▶ If the mains voltage lies outside the tolerances given in the technical data, do not under any circumstances connect the device to the mains.
-

The cleaning device is designed to operate at the mains voltage indicated on the rating plate. The fuse protection required for the mains lead can be found in the "Technical data" section. If there is no mains cable or mains plug on your version of the appliance, fit one that conforms to national standards.

Bolting the cleaning device to the underlying surface (foundation)

Screwing the cleaning device and installation stand to the underlying surface (foundation)

WARNING!

Danger from machines falling or toppling over.

This can result in serious injury and damage to property.

- ▶ The device should only ever be set up with the designated installation stand.
- ▶ Different fixings may be required to connect the installation stand to the underlying surface (foundation) depending on the nature of this surface.
- ▶ The fixings required to connect the installation stand to the underlying surface (foundation) are not included in the scope of supply of the installation stand. The screws included in the scope of supply of the installation stand are not suitable for fixing the installation stand to the underlying surface. The installer is responsible for selecting the right type of fixing.

- 1** Place the optionally available installation stand on a level, firm and vibration-free surface (foundation)
 - Position the installation stand in such a way that the distance the robot has to travel to the cleaning device on the installation stand is as short as possible
- 2** Screw the installation stand to the underlying surface (foundation) using the appropriate fixings

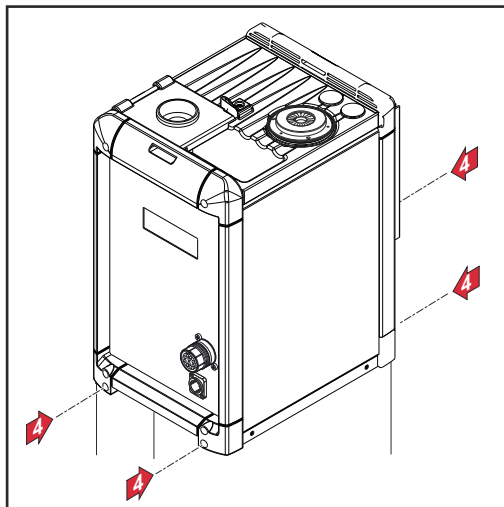

- 3** Position the cleaning device on the installation stand
- 4** Screw the cleaning device to the installation stand using the four screws supplied with the cleaning device

Connecting the mains cable

Connecting the mains cable

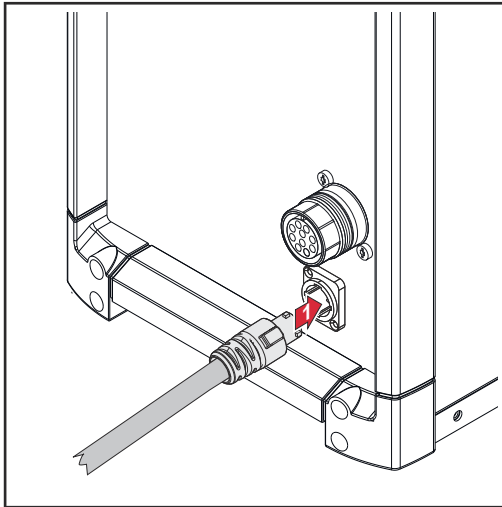

- 1 Connect the mains cable:
 - Plug in the mains cable
 - Turn the mains cable 45° to the right until you hear it latch into place

Installing the wire cutter

Installing the wire cutter on the cleaning device

NOTE!

Wire cutters for conventional applications (one wire electrode) and for twin applications (two wire electrodes) are installed in the same way - as described below.

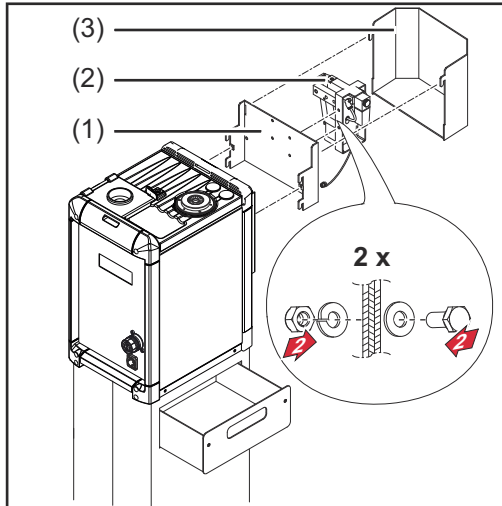

- 1 Attach the wire cutter holder (1) to the cleaning device
- 2 Fix the wire cutter (2) to the holder (1) using the two screws, two washers, two lock washers and two nuts as shown. The installer is responsible for selecting the correct screws, washers, lock washers and nuts
- 3 Attach the protective cover (3) to the holder (1)
- 4 If using an electrically controlled wire cutter: Plug the wire cutter connecting cable into the wire cutter connection on the cleaning device

NOTE!

The wire cutter cannot be supplied with compressed air from the cleaning device.

The wire cutter must be supplied with compressed air from a separate supply line.

Maximum wire diameter

For conventional applications (one wire electrode), wire electrodes with a diameter of up to 1.6 mm (0.063 in.) can be cut by the respective wire cutter.

For twin applications (two wire electrodes), two wire electrodes with diameters of up to 1.6 mm (0.063 in.) can be cut simultaneously by the respective wire cutter.

How the mechanically controlled wire cutter works

NOTE!

Wire cutters for twin applications may differ slightly in appearance from the one shown in the following figure.

Wire cutters for conventional applications (one wire electrode) and for twin applications (two wire electrodes) work in the same way - as described below.

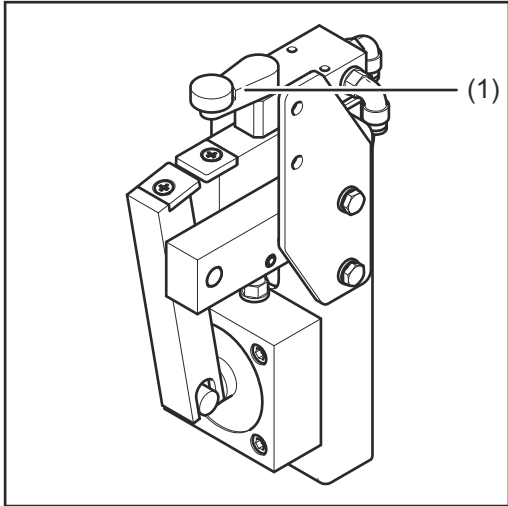

If a torch neck pushes the valve lever (1) to the side by more than 15° with the gas nozzle, the wire cutter is activated and the wire electrode is cut.

NOTE!

The wire electrode is cut while the torch neck is moving.

Mechanically controlled wire cutter for conventional applications (using one wire electrode)

How the electrically-controlled wire cutter works

The electrically-controlled wire cutter opens and closes when there is an active signal from the robot control.

Filling the dipping bowl with parting agent

Filling the dipping bowl with parting agent

NOTE!

Only use the "Robacta TC Cool +" parting agent supplied by the manufacturer. The composition of the manufacturer's parting agent is intended specifically for the Robacta TC. If other manufacturers' products are used, trouble-free operation cannot be guaranteed.

- 1 Fold out the container holder containing the empty "Robacta TC Cool +" parting agent container
- 2 Remove the empty "Robacta TC Cool +" parting agent container and dispose of it according to national regulations
- 3 Open a new "Robacta TC Cool +" parting agent container and put it into the holder
- 4 Fold the container holder containing the full "Robacta TC Cool +" parting agent container carefully back above the dipping bowl
 - The optimum fill-level is regulated automatically

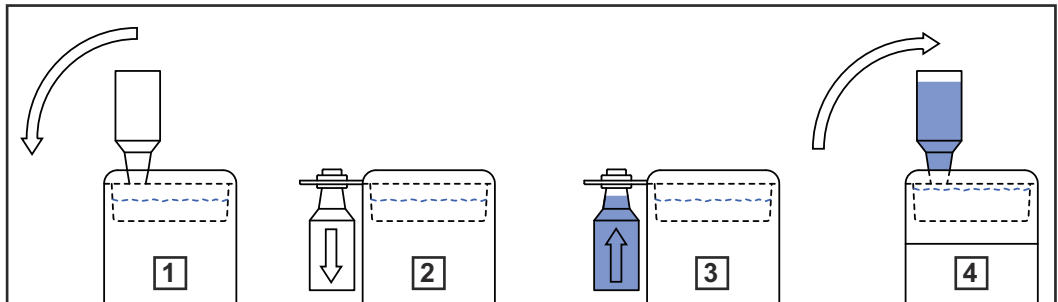

NOTE!

Carry out the following maintenance on the dipping bowl at weekly intervals:

- ▶ Take the spill tray out of the dipping bowl and dispose of any accumulated dirt
- ▶ Check the consistency of the "Robacta TC Cool +" parting agent. If the "Robacta TC Cool +" parting agent is thick, add fresh water and stir to mix in
- ▶ Check the level sensor in the dipping bowl for dirt and clean if necessary

NOTE!

Carry out the following maintenance on the dipping bowl every three months:

- ▶ Drain all the parting agent from the dipping bowl
- ▶ Take the spill tray out of the dipping bowl and dispose of any accumulated dirt
- ▶ Clean the dipping bowl and spill tray
- ▶ Fill the dipping bowl with new parting agent

Take care never to damage the level sensor when performing maintenance work.

Connecting the cleaning device to the "Robacta Reamer" parting agent container

Connecting the cleaning device to the "Robacta Reamer" parting agent container

NOTE!

Only use "Robacta Reamer" parting agent supplied by the manufacturer.

The composition of the manufacturer's parting agent is intended specifically for the Robacta TC. If other manufacturers' products are used, trouble-free operation cannot be guaranteed.

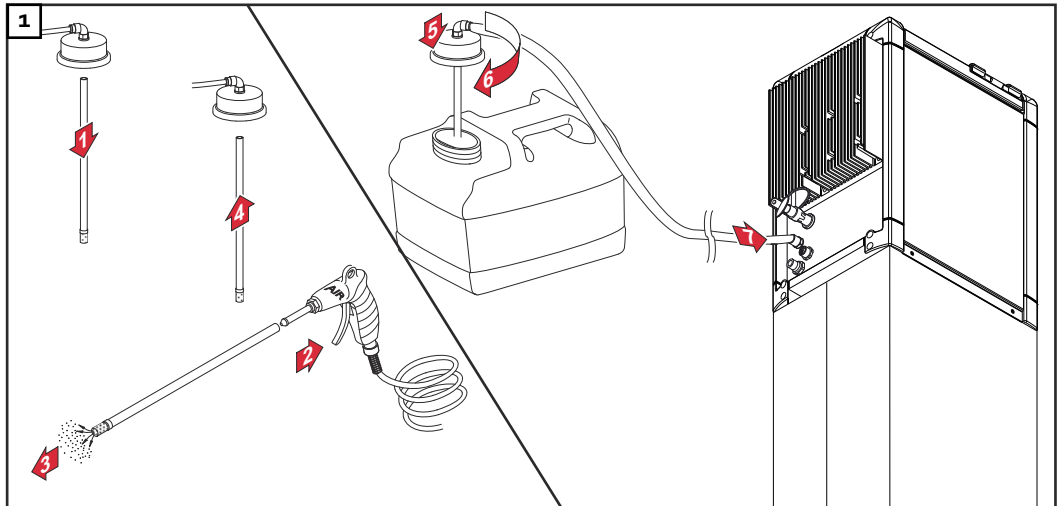

NOTE!

The parting agent spray time must be set on the robot control.

A minimum spray time of 0.5 seconds can be set.

A spray time of approx. 0.7 seconds is recommended. This may vary depending on the size of the gas nozzle.

Starting up the cleaning device

General

NOTE!

Not coating the interior of the welding torch may result in permanent soiling of the torch when welding begins.

Always wet the inside of the welding torch with the manufacturer's "Robacta Reamer" parting agent before starting automatic operation.

To achieve the best cleaning results, please note the following:

- Apply an even layer of parting agent to the inside of the torch
- Follow the cleaning sequences as described below
- Keep to the specified cleaning positions
- Blow out the welding torch with compressed air during the cleaning operation (however not when parting agent is being actively sprayed into the torch interior)

NOTE!

Single, small bits of welding spatter cannot be removed by the cleaning device.

However, these small pieces do not influence the welding process.

Prerequisites for start-up

The following requirements must be met before the cleaning device is started up:

- Cleaning device is bolted to underlying surface
- If present, connect the "Robacta Reamer" parting agent container to the cleaning device
- If using the dipping bowl, the dipping bowl is filled with the "Robacta TC Cool +" parting agent
- If present, wire cutter installed and supplied with compressed air
- Cleaning device connected to mains
- If the cleaning device has been connected to the "Robacta Reamer" parting agent container: compressed air supply to cleaning device has been established
- Cleaning device connected to robot control

Gas nozzle to spool body distance control

When the welding torch is in the spool (correct insertion depth), the torch must be free to move in every direction.

To check whether the torch has sufficient freedom of movement, it must have to be firmly pressed by hand in 4 directions before it will touch the spool wall.

Cleaning program sequence - Robacta TC 2000, Robacta TC 2000 US

Program sequence with parting agent nebuliser - overview

1. Weld
2. Clean gas nozzle tip and nozzle fitting
3. Spray parting agent
4. Weld

Program sequence with parting agent nebuliser and dipping bowl - overview

1. Weld
2. Cool welding torch in dipping bowl
3. Clean gas nozzle tip and nozzle fitting
4. Spray parting agent
5. Weld

Cooling welding torch in the dipping bowl - detailed description

Immersing the hot welding torch in the "Robacta TC Cool / Robacta TC Cool MD" parting agent has the following benefits:

- The spatter that has accumulated on the gas nozzle is loosened
- The welding torch is cooled down more
- The anti-adhesive agent in the "Robacta TC Cool / Robacta TC Cool MD" parting agent prevents renewed soiling

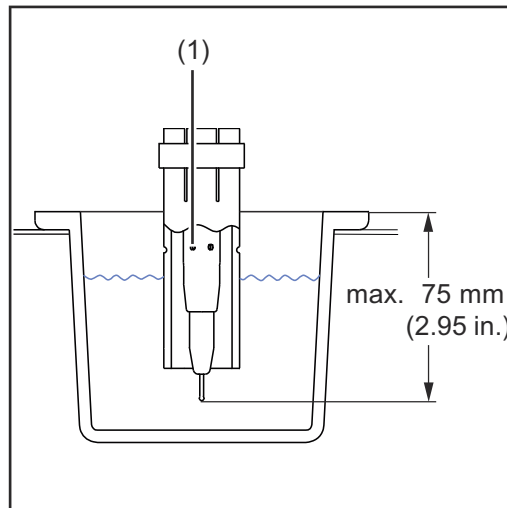

- 1 After welding, position the welding torch approximately 50 mm (1.97 in.) above the dipping bowl

NOTE!

Do not dip the welding torch more than 75 mm (2.95 in.) into the dipping bowl. The gas holes (1) must remain dry.

- 2 Dip the welding torch vertically into the dipping bowl
- 3 Depending on the application, hold the welding torch in the dipping bowl for approximately 1 - 4 seconds so that any air in the torch can escape and the torch can cool sufficiently
- 4 Raise the welding torch back to its original position above the dipping bowl
- 5 Allow the welding torch to drip for approximately 1 - 4 seconds or blow down it with compressed air using the hosepack before bringing it back to its original position for cleaning

Cleaning the gas nozzle tip and nozzle fitting - detailed description

NOTE!

During the cleaning operation, blow out the welding torch with compressed air through the hosepack - any remaining dirt or parting agent is removed.

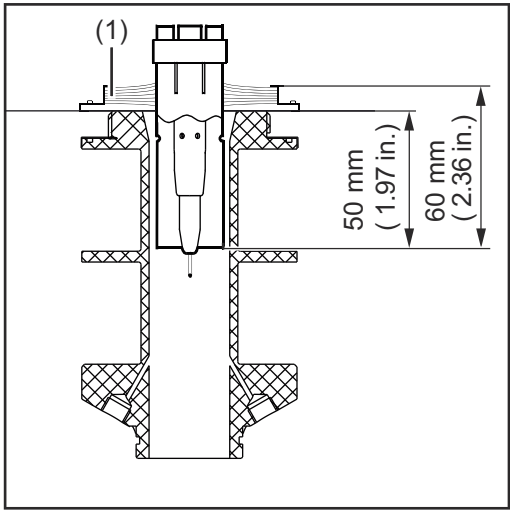

NOTE!

Ensure that the gas nozzle does not touch the housing components of the cleaning opening at any time.

- 1 Position the welding torch approximately 50 mm (1.97 in.) centrally above the middle of the cleaning opening

NOTE!

If the brush seal (1) is fitted, note the changed reference point when positioning the welding torch.

- 2 Move the welding torch vertically into the cleaning position - see figure
- 3 Begin cleaning and hold the welding torch for approximately 1 second in the cleaning position

Spraying parting agent - detailed description

Applying parting agent evenly has the following advantages:

- reduced welding spatter accumulation
- prevents re-soiling

NOTE!

If the brush seal (1) is fitted, note the changed reference point when positioning the welding torch.

NOTE!

Ensure that the gas nozzle does not touch the housing components of the cleaning opening at any time.

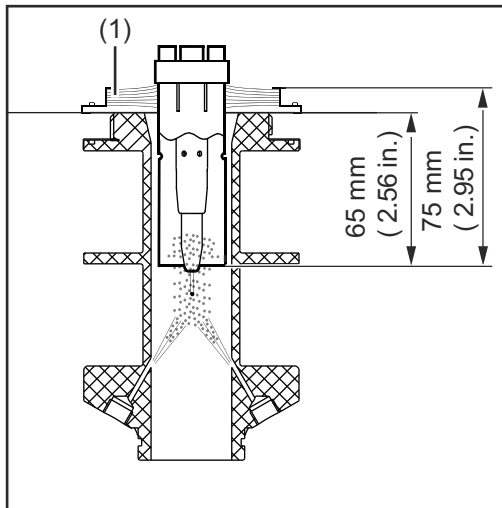

- 1 Place the welding torch in the spray position
 - see figure

NOTE!

During the spraying process, ensure that compressed air is not blown out through the welding torch.

- 2 Spray welding torch with parting agent for approximately 0.7 seconds
- 3 Move the welding torch to the start position above the cleaning opening - approximately 50 mm (1.97 in.) centrally above the middle of the cleaning opening
 - The cleaning operation is complete and the welding torch is ready for use again
- 4 Ensure that not too much parting agent has accumulated on the gas nozzle (no droplet formation). If this is the case :
 - Reduce the spray time or
 - After the cleaning operation, blow out the welding torch with compressed air using the hosepack

Cleaning program sequence with parting agent nebuliser

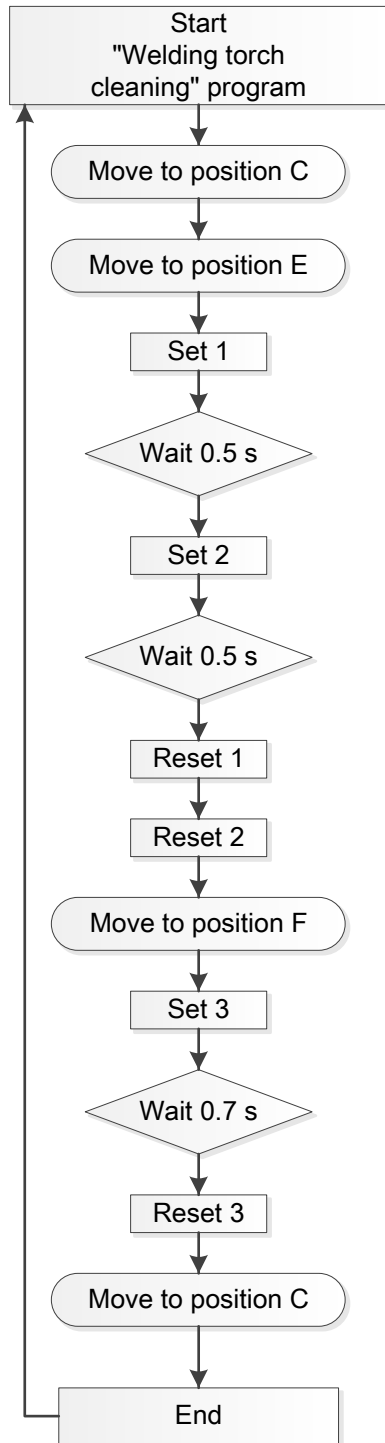

- Set 1/Reset 1
Blow compressed air through torch

- Set 2/Reset 2
"Start cleaning" signal

- Set 3/Reset 3
"Spray parting agent" signal

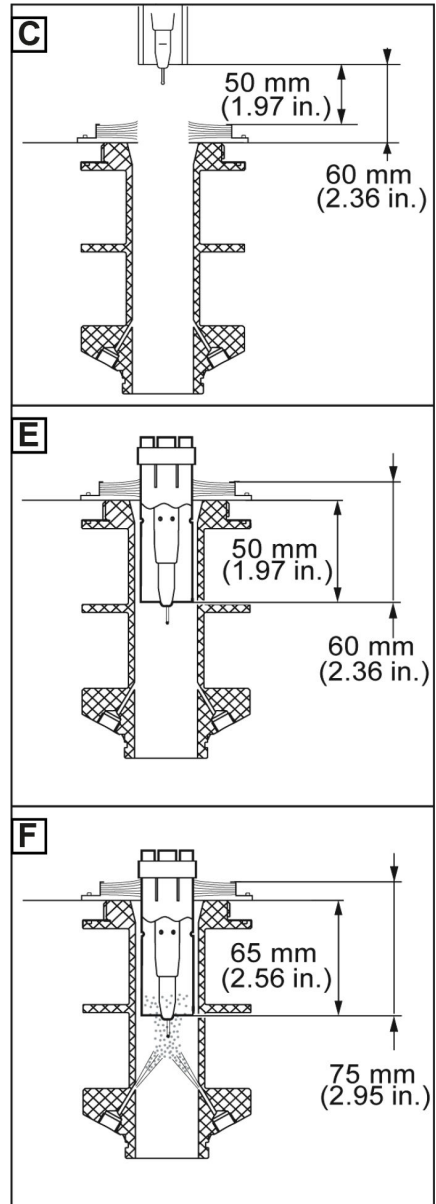

Cleaning program sequence with dipping bowl

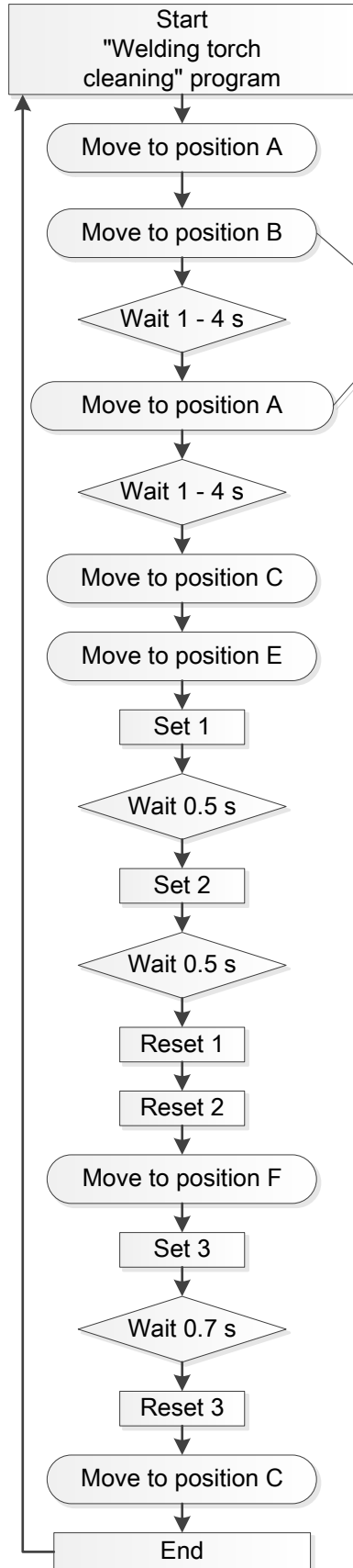

Set 1/Reset 1
Blow compressed air through welding torch

Set 2/Reset 2
"Start cleaning" signal

Set 3/Reset 3
"Spray parting agent" signal

$V_{max} = 10 \text{ cm/s}$
(236.22 ipm)

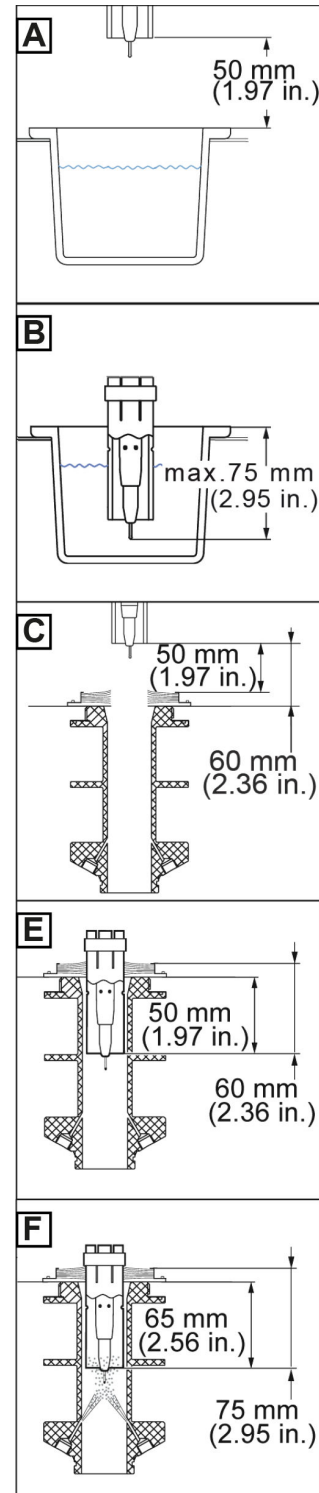

Cleaning program sequence - Robacta TC 2000 Twin, Robacta TC 2000 Twin US

Program sequence with parting agent nebuliser - overview

1. Weld
2. Clean gas nozzle tip and nozzle fitting
3. Spray parting agent
4. Weld

Program sequence with parting agent nebuliser and dipping bowl - overview

1. Weld
2. Cool welding torch in dipping bowl
3. Clean gas nozzle tip and nozzle fitting
4. Spray parting agent
5. Weld

Cooling welding torch in the dipping bowl - detailed description

Immersing the hot welding torch in the "Robacta TC Cool / Robacta TC Cool MD" parting agent has the following benefits:

- The spatter that has accumulated on the gas nozzle is loosened
- The welding torch is cooled down more
- The anti-adhesive agent in the "Robacta TC Cool / Robacta TC Cool MD" parting agent prevents renewed soiling

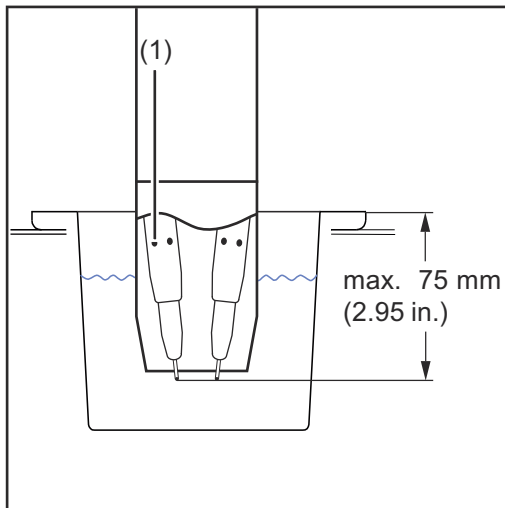

- 1 After welding, position the welding torch approximately 50 mm (1.97 in.) above the dipping bowl

NOTE!

Do not dip the welding torch more than 75 mm (2.95 in.) into the dipping bowl. The gas holes (1) must remain dry.

- 2 Dip the welding torch vertically into the dipping bowl

- 3 Depending on the application, hold the welding torch in the dipping bowl for approximately 1 - 4 seconds so that any air in the torch can escape and the torch can cool sufficiently
- 4 Raise the welding torch back to its original position above the dipping bowl
- 5 Allow the welding torch to drip for approximately 1 - 4 seconds or blow down it with compressed air using the hosepack before bringing it back to its original position for cleaning

Cleaning the gas nozzle tip and nozzle fitting - detailed description

NOTE!

During the cleaning operation, blow out the welding torch with compressed air through the hosepack - any remaining dirt or parting agent is removed.

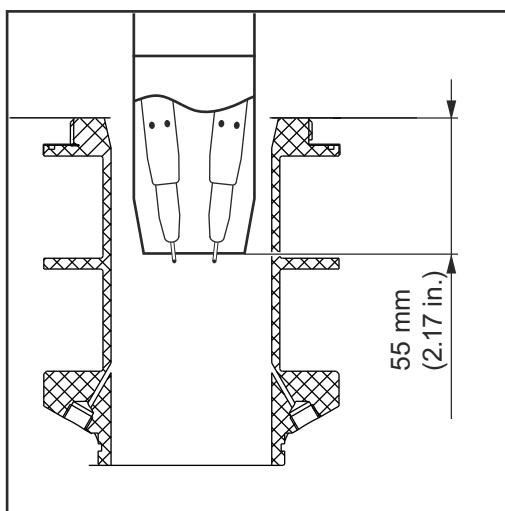

NOTE!

Ensure that the gas nozzle does not touch the housing components of the cleaning opening at any time.

- 1 Position the welding torch approx. 50 mm (1.97 in.) centrally above the middle of the cleaning opening
- 2 Move the welding torch vertically into the cleaning/spray position - see figure
- 3 Begin cleaning and wait for approx. 1 second

Spraying parting agent - detailed description

Applying parting agent evenly has the following advantages:

- reduced welding spatter accumulation
- prevents re-soiling

NOTE!

Ensure that the gas nozzle does not touch the housing components of the cleaning opening at any time.

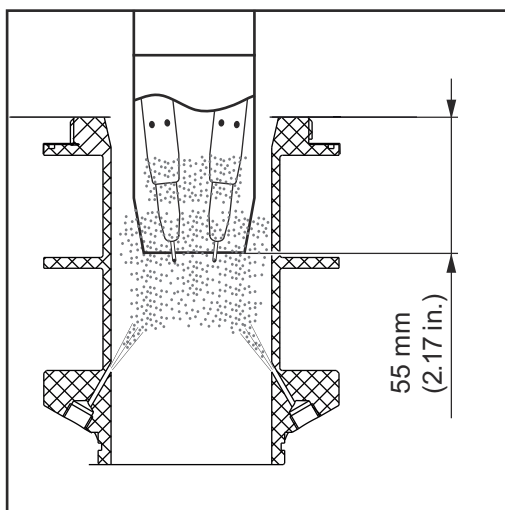

- 1 Maintain cleaning/spray position - see figure

NOTE!

Do not blow compressed air through the welding torch during the spraying process.

- 2 Spray welding torch with parting agent for approx. 0.7 seconds

- 3 Move the welding torch to the start position above the cleaning opening - approx. 50 mm (1.97 in.) centrally above the middle of the cleaning opening - The cleaning operation is complete and the welding torch is ready for use again

- 4 Ensure that not too much parting agent has accumulated on the gas nozzle (no droplet formation). If this is the case:
- Reduce the spray time or
 - After the cleaning operation, blow out the welding torch with compressed air using the hosepack

Cleaning program sequence with parting agent nebuliser

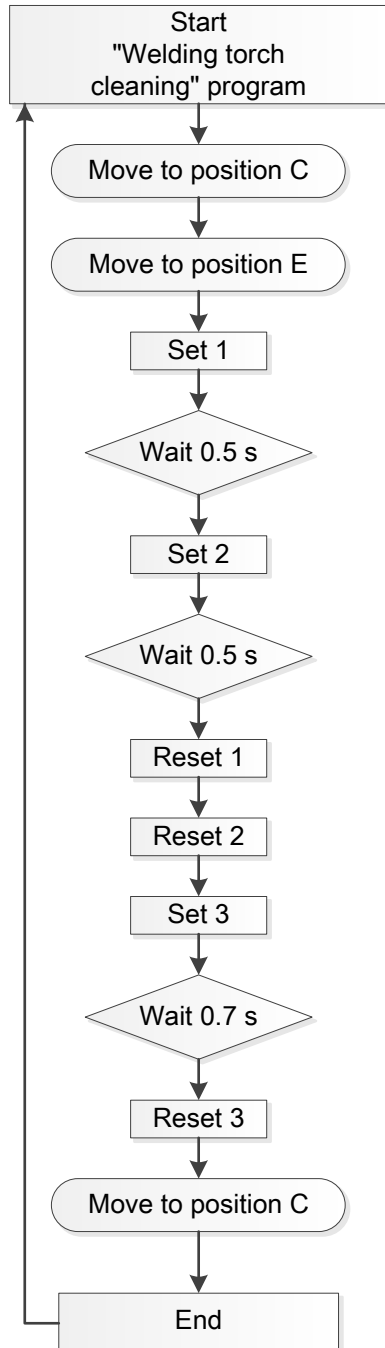

Set 1/Reset 1
Blow compressed air through welding torch

Set 2/Reset 2
"Start cleaning" signal

Set 3/Reset 3
"Spray parting agent" signal

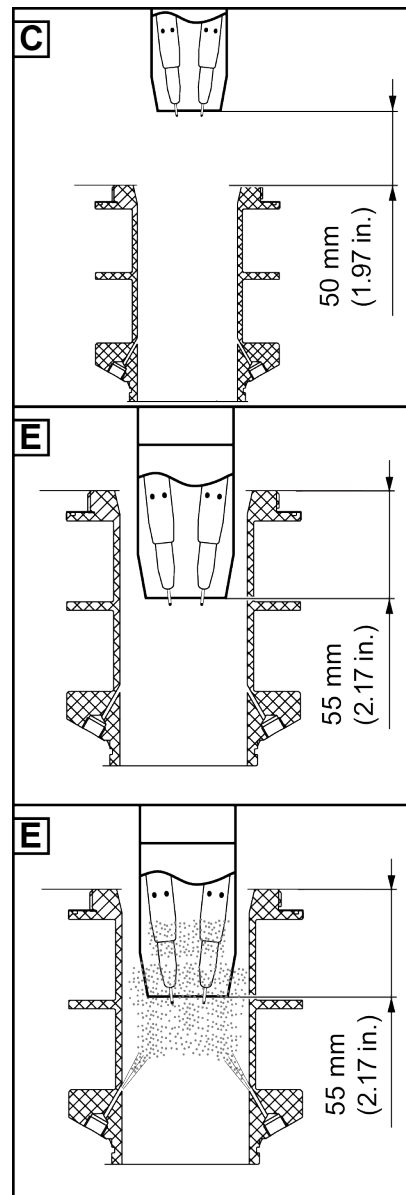

Cleaning program sequence with dipping bowl

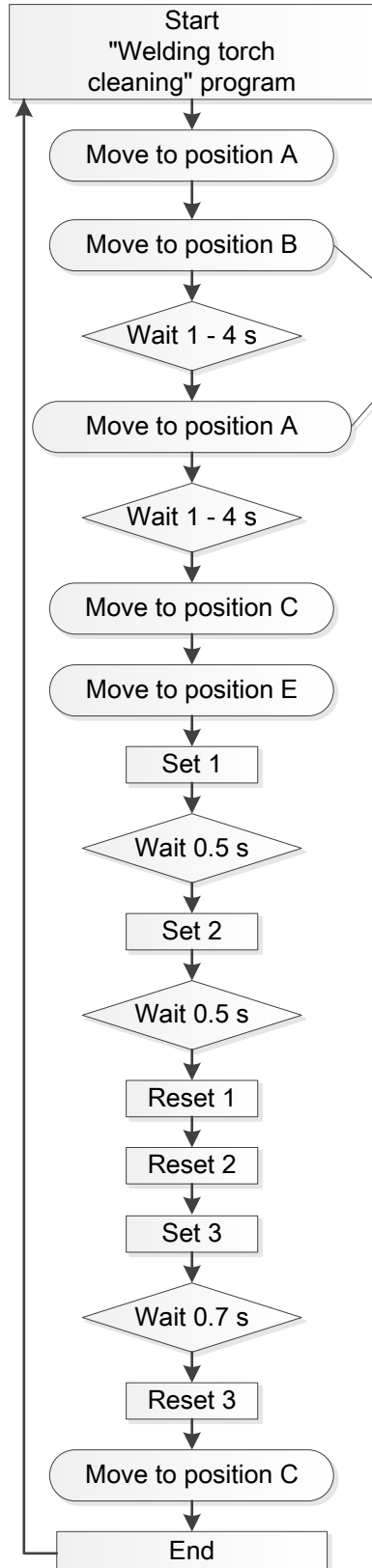

Set 1/Reset 1
Blow compressed air through welding torch
Set 2/Reset 2
"Start cleaning" signal
Set 3/Reset 3
"Spray parting agent" signal

$V_{max} = 10 \text{ cm/s}$
(236.22 ipm)

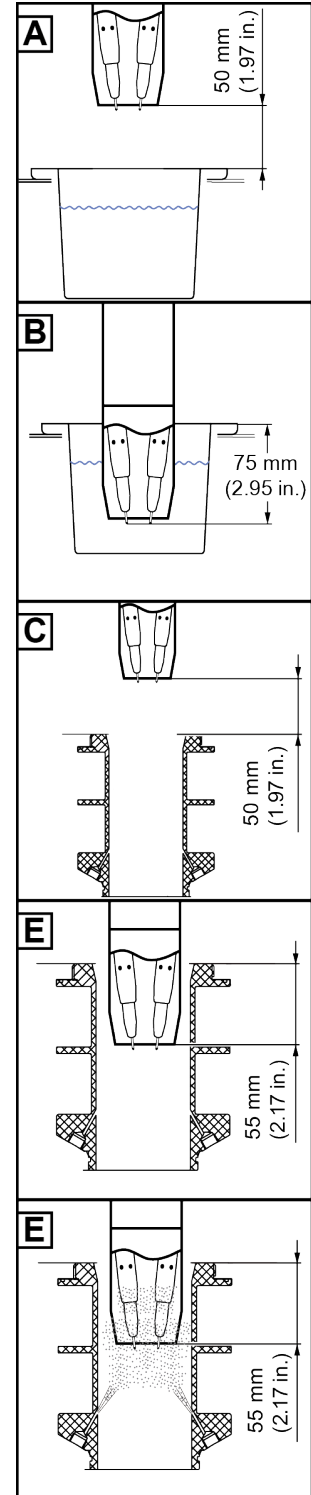

Troubleshooting, maintenance and disposal

Safety

Observe the following safety rules for all work described in the "Troubleshooting, maintenance and disposal" section.

WARNING!

Danger from incorrect operation and work that is not carried out properly.

This can result in serious personal injury and damage to property.

- ▶ All the work and functions described in this document must only be carried out by a trained Fronius service technician.
- ▶ Read and understand this document in full.
- ▶ Read and understand all safety rules and user documentation for this device and all system components.

WARNING!

Risk of machines starting automatically.

This can result in serious personal injury and damage to property.

- ▶ In addition to these Operating Instructions, also observe the safety rules issued by the manufacturer of the robot and welding system.
- ▶ Ensure that all protective measures have been taken and will remain in place while you are in the working area of the robot.

WARNING!

Danger from electric current and mechanically powered parts.

This can result in serious personal injury and damage to property.

- ▶ Before working on the cleaning device or the associated system components, disconnect the customer's compressed air and power supply from the cleaning device and the associated system components.
- ▶ Ensure that they remain disconnected until all work is complete.

WARNING!

**Whenever the cleaning device is supplied with voltage and/or compressed air, a risk of serious injury exists from:
the magnetic field of the cleaning opening
flying parts (shavings, etc.)
compressed air/parting agent mixture escaping from the cleaning opening
activated wire cutter**

This can result in serious personal injury and damage to property.

If work has to be performed on the cleaning device while it is being supplied with voltage and/or compressed air, take the following protective measures:

- ▶ Keep all ferromagnetic parts away from the device (e.g. tools).
- ▶ Keep your body, especially your hands, face and hair, any objects and all clothing away from the cleaning opening and the wire cutter.
- ▶ Wear ear protection.
- ▶ Wear protective goggles with side protection.



WARNING!

Danger from inadequate ground conductor connection.

This can result in serious personal injury and damage to property.

- ▶ The housing screws provide a suitable ground conductor connection for earthing the housing and must NOT be replaced by any other screws which do not provide a reliable ground conductor connection.
-

Troubleshooting Make a note of the serial number and configuration of the device and contact our After-Sales Service team with a detailed description of the error, if

- errors occur that are not listed below
- the troubleshooting measures listed are unsuccessful

Mains voltage indicator not lit

Mains cable connected

Cause: Faulty mains cable

Remedy: Check mains cable

"Ready-to-clean" signal not transmitted to robot control

Mains voltage indicator lit

Cause: Quick Stop is active (HI - Quick Stop = LO / LO - Quick Stop = HI)

Remedy: Deactivate Quick Stop (HI - Quick Stop = HI / LO - Quick Stop = LO)

Cause: Supply to I/O standard connection socket (X1) is faulty

Remedy: Depending on the connection socket, check the assignment of inputs "B" and "H" / "D" and "G"

Cause: Temperature sensor is faulty

Remedy: Change cleaning coil

Ready-to-clean signal not transmitted to robot control

Mains voltage indicator lit, overtemperature indicator lit

Cause: The cleaning device is overheating

Remedy: Allow cleaning device to cool down. Once the permitted operating temperature has been reached, charging of the capacitors starts again. The cleaning device is then ready to clean again

Fill level indicator lit

The liquid in the dipping bowl is below the optimum fill level

Cause: "Robacta TC Cool / Robacta TC Cool MD" parting agent container is empty

Remedy: Replace "Robacta TC Cool / Robacta TC Cool MD" parting agent container

Fill level indicator lit

The "Robacta TC Cool / Robacta TC Cool MD" parting agent container is not yet empty

Cause: Level sensor is dirty

Remedy: Clean level sensor with fresh water

Cause: Level sensor faulty

Remedy: Contact After-Sales Service

Fill level indicator lit

A dipping bowl is not available or is not being used

Cause: A parting agent nebuliser is being used

Remedy: Not necessary

Fill level indicator not lit

The liquid in the dipping bowl is already below the optimum fill level

Cause: Fill-level sensor faulty

Remedy: Contact After-Sales Service

The parting agent does not spray

The "Robacta Reamer" parting agent container is full

Cause: Not enough spray

Remedy: Adjust spray amount (spray time)

Cause: Dirty suction filter in "Robacta Reamer" parting agent container

Remedy: Blow compressed air through the suction filter in the "Robacta Reamer" parting agent container from the inside outwards using the suction hose
(see section [Connecting the cleaning device to the "Robacta Reamer" parting agent container](#) on page 47)

Cause: Compressed air supply interrupted

Remedy: Establish the compressed air supply

Cause: Compressed air supply line faulty or dirty

Remedy: Clean compressed air supply line, replace if necessary

Cause: Faulty vacuum pump

Remedy: Contact After-Sales Service (arrange for vacuum pump to be replaced)

Cause: Faulty solenoid valve

Remedy: Contact After-Sales Service (arrange for solenoid valve to be replaced)

Parting agent does not spray

Cause: The "Robacta Reamer" parting agent container is empty

Remedy: Fill with parting agent

Cause: Interconnecting hosepack damaged

Remedy: Contact After-Sales Service

Pores in the weld seam

Cause: Too much parting agent inside the welding torch

Remedy: Remove parting agent residue by blowing out the torch interior. Ensure supply of compressed air

Cause: Too much parting agent inside the welding torch

Remedy: Reduce amount of parting agent spray (shorten duty cycle of pump for parting agent)

Error is sent to the robot. Overtemperature and fill level indicators flash at the same time, no cleaning takes place

Cause: Quick Stop is active (HI - Quick Stop = LO / LO - Quick Stop = HI)

Remedy: Deactivate Quick Stop (HI - Quick Stop = HI / LO - Quick Stop = LO)

Cause: Fault in the cleaning device

Remedy: Disconnect the cleaning device from the mains and wait for approx. 1 minute before reconnecting it to the mains

Contact After-Sales Service if this does not remedy the situation

Care, maintenance and disposal

Before each start-up

- Check the fill level in the "Robacta Reamer" parting agent container and the dipping bowl, top up if necessary

NOTE!

The "Robacta TC Cool / Robacta TC Cool MD" and "Robacta Reamer" parting agents differ in their composition.

Use the appropriate medium depending on the application concerned.

Daily

NOTE!

Only use solvent-free cleaning products on the devices.

- 1 Remove any deposits of parting agent or contaminants from the outside of the base and cleaning units.

Weekly

- Empty the spatter tray for welding residues
- Take the spill tray out of the dipping bowl and dispose of any accumulated dirt
- Check the consistency of the "Robacta TC Cool / Robacta TC Cool MD" parting agent. If the "Robacta TC Cool / Robacta TC Cool MD" parting agent is viscous, add fresh water and stir to mix with the parting agent
- Check the level sensor in the dipping bowl for dirt and clean if necessary
- Clean the cleaning opening on the inside
- Check the "Robacta Reamer" and "Robacta TC Cool / Robacta TC Cool MD" parting agent containers for soiling and clean if necessary
- Blow compressed air through the suction filter in the "Robacta Reamer" parting agent container from the inside outwards using the suction hose (see "Connecting the cleaning device to the "Robacta Reamer" parting agent container")
- Check the condition of the brush seal above the cleaning opening. Replace the brush seal if worn (not applicable for twin devices)

Every 3 months

NOTE!

Take care never to damage the level sensor when performing maintenance work.

Robacta TC 1000:

- 1 Drain all the parting agent from the dipping bowl
- 2 Take the spill tray out of the dipping bowl and dispose of any accumulated dirt
- 3 Clean the dipping bowl and spill tray
- 4 Fill the dipping bowl with new parting agent

Every 6 months**NOTE!**

Do not bring the air nozzle too close to electronic parts.

- 1** Robacta TC 1000 / Robacta TC 1000 ext. Open (base unit and cleaning unit) and blow clean using dry reduced compressed air
-

Every 12 months

- 1** Arrange for a safety inspection to be carried out on the cleaning device by a Fronius service engineer
-

Disposal

Dispose of in accordance with the applicable national and local regulations.

Technical data

Technical data

General



CAUTION!

Danger due to insufficiently dimensioned electrical installations.

This can result in severe damage to property.

- ▶ Dimension the mains lead and its fuse to suit the device being used. The technical data shown on the rating plate applies.

Robacta TC 2000, Robacta TC 2000 Twin

Mains voltage	230 V
Mains voltage tolerance	-10% / +10%
Mains frequency	50/60 Hz
Nominal output	180 W
Mains fuse protection (slow-blow)	10 A
Compressed air supply	6 bar 86.99 psi
Minimum cleaning interval	from 20 s
Dipping bowl minimum capacity	0.75 l 0.20 gal.
Degree of protection	IP 21
Dimensions l/w/h	330 / 250 / 422 mm 12.99 / 9.84 / 16.61 in.
Weight (without "Robacta TC Cool / Robacta TC Cool MD" parting agent)	24.4 kg 53.79 lb.
EMC emission class	A
Mark of conformity	CE, CSA

Robacta TC 2000 US, Robacta TC 2000 Twin US

Mains voltage	110 V
Mains voltage tolerance	-5% / +5%
Mains frequency	50/60 Hz
Nominal output	180 W
Mains fuse protection (slow-blow)	10 A
Compressed air supply	6 bar 86.99 psi
Minimum cleaning interval	from 20 s
Dipping bowl minimum capacity	0.75 l 0.20 gal.
Degree of protection	IP 21

Dimensions l/w/h	330 / 250 / 422 mm 12.99 / 9.84 / 16.61 in.
Weight (without "Robacta TC Cool / Robacta TC Cool MD" parting agent)	24.4 kg 53.79 lb.
EMC emission class	A
Mark of conformity	CE, CSA



Fronius International GmbH

Froniusstraße 1
4643 Pettenbach
Austria
contact@fronius.com
www.fronius.com

At www.fronius.com/contact you will find the contact details
of all Fronius subsidiaries and Sales & Service Partners.